



## Formulation of a Mathematical Model for the Transmission Dynamics of Infectious Bursal Disease (IBD), Incorporating Effects of Environmental Factors

Emily Atieno Omollo<sup>1\*</sup> and George Kimathi<sup>1</sup>

<sup>1</sup>Catholic University of Eastern Africa (CUEA), P.O. Box 62157-00200, Nairobi, Kenya.

### Authors' contributions

This work was carried out in collaboration between both authors. Author EAO designed the study, performed the statistical analysis, wrote the protocol, and wrote the first draft of the manuscript. Author GK and Author EAO managed the analyses of the study. Author EAO managed the literature searches. Both authors read and approved the final manuscript.

### Article Information

DOI: 10.9734/ARJOM/2020/v16i930217

Editor(s):

(1) Dr. Ruben Dario Ortiz Ortiz, Universidad Michoacana de San Nicols de Hidalgo, Mexico.

Reviewers:

(1) Manisha Nagpal, Sri Guru Ram Das Institute of Medical Sciences & Research, India

(2) Guichen Lu, Chongqing University of Technology, China.

Complete Peer review History: <http://www.sdiarticle4.com/review-history/59641>

Received: 06 June 2020

Accepted: 12 August 2020

Published: 21 August 2020

Original Research Article

## Abstract

In this paper, we develop a four compartment model that explain the transmission dynamics of infectious bursal disease, considering the effects of environmental factors. Ordinary differential equations have been used in formulation of the model. Reproductive number ( $R_0$ ) has been derived using Next Generation Matrix. The disease free equilibrium is analyzed using Jacobian matrix and found to be locally and globally asymptotically stable when  $R_0 < 1$ . We employ Routh-Hurwitz stability criterion to analyze the stability of endemic equilibrium. The numerical results indicates that contact with contaminated environment enhances the rate of transmission of the disease in the system.

*Keywords:* Infectious bursal disease; reproductive number; environmental contact rate; disease free equilibrium; endemic equilibrium.

\*Corresponding author: E-mail: [melatieno79@gmail.com](mailto:melatieno79@gmail.com);

## 1 Introduction

Infectious bursal disease also known as Gumboro disease is a viral disease which is highly infectious and affects young chickens of 3-6 weeks old. According to Van den Berg [1], a severe and acute outbreak of the disease in poultry farm causes 100% morbidity and mortality rate is also high, but the less acute or sub-clinical disease is common in 0-3 week old birds [1]. Chicks at this age are protected by passive immunity acquired from the parents. When the strain of the virus is of low virulence it causes less than 2% specific mortality and can be successfully controlled by vaccination [2]. The disease is caused by Infectious Bursal Disease Virus (IBDV), which is a member of *birnavirus* genus. The virus consist of two segment of double-stranded ribonucleic acid (RNA), which has no envelop, which make it highly resistant to the outside environment [3]. IBD virus is highly resistant to environmental exposure and is transmitted laterally by direct or indirect contact between the environment, susceptible and infected flocks [2]. The virus is very difficult to eliminate since it is extremely hardy and can survive in a wide range of environmental conditions [3, 4]. Due to the resistance nature of the virus, it is hard to clear it with most disinfectants and environmental factors, making poultry houses to be contaminated with IBD Virus that persist on the premises and tend to reappear in subsequent flock [5]. When chickens below 3 weeks old are infected by infectious bursal disease they show no detectable sign which is the most economically important as the disease can lead to severe long lasting suppression of the immune system, while those of 3-6 weeks old are mostly susceptible to clinical symptoms of the disease. Birds infected by IBD virus shed the virus in their feces thereby contaminating feeds, water and their house. The other birds in the house become infected by ingesting the virus [6]. IBDV remains infectious in the house for 122 days and 52 days in the feed and water respectively. Due to the hardy state of the virus, strict hygiene should be observed in poultry management and vaccination of the chickens should be done at tender age to curb the disease [7]. Infectious bursal disease is associated with great economic losses in poultry enterprises and it has been of great concern to poultry industries [8]. The economic impact caused by IBDV is difficult to assess due to the complex nature of the losses associated with gumboro disease [5]. And lack of adequate responses to vaccinations and against other diseases, destroys the immune response rendering the chicks susceptible to various infections responsible for the greatest economic losses in the affected flocks [9, 10].

In this paper, we develop a MSIR mathematical model to study the transmission dynamics of Infectious bursal disease considering the effect of environment. We paid more attention on the effects of contact with the contaminated environment by the infectious bursal disease virus.

### Aim of the study

This study aims at investigating the effects of environmental factors in transmission dynamics of infectious bursal disease.

### Objectives of the study

- i) To formulate a mathematical model for the transmission dynamics.
- ii) To derive reproductive number.
- iii) To carry out stability analysis of the model.
- iv) To perform numerical analysis on the effects of contact with the environment.

## 2 Model Formulation

In this section, we formulate a four compartment model MSIR for transmission dynamics of infectious bursal disease. The total population ( $N$ ) is divided into four classes: The passive immune class ( $M$ ), Susceptible ( $S$ ), Infected ( $I$ ) and Recovery ( $R$ ).

The total population with respect to all the compartments is given by;

$$N(t) = M(t) + S(t) + I(t) + R(t).$$

The schematic diagram below shows how the disease spreads.

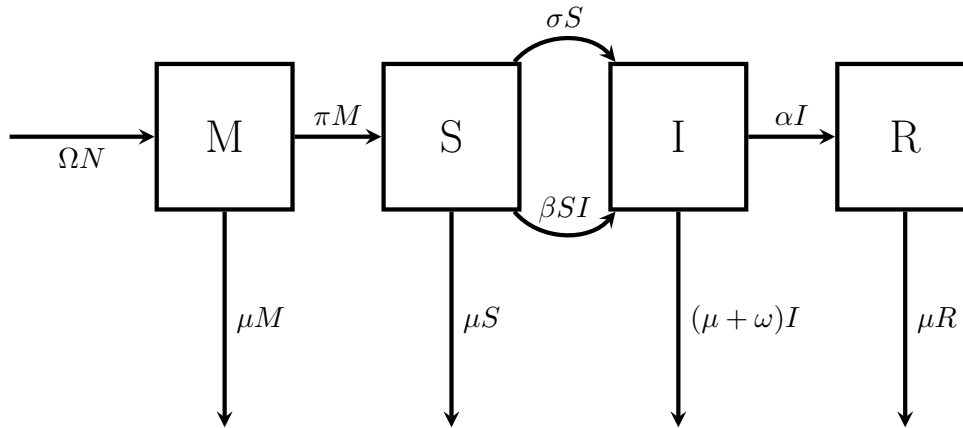

**Fig. 1. Schematic diagram showing the transmission dynamics of Gumboro disease**

The mathematical equations of the model are described by a system of ordinary differential equations given below:

$$\begin{aligned} \frac{dM}{dt} &= \Omega N - (\pi + \mu)M, \\ \frac{dS}{dt} &= \pi M - \beta IS - (\sigma + \mu)S, \\ \frac{dI}{dt} &= \beta IS + \sigma S - (\omega + \alpha + \mu)I, \\ \frac{dR}{dt} &= \alpha I - \mu R. \end{aligned} \tag{2.1}$$

and

$$\frac{dN}{dt} = (\Omega - \mu)N - \omega I.$$

with initial conditions;  $M(0) = M_0 > 0$ ,  $S(0) = S_0 \geq 0$ ,  $I(0) = I_0 \geq 0$ ,  $R(0) = R_0 \geq 0$ .

Tables 1 and 2 indicates the description of the variables and parameters used.

**Table 1. The variable used in the model**

Variable	Description
M	Passive immune
S	Susceptible
I	Infectious
R	Recovery

**Table 2. The Parameters used in the model**

Parameter	Description
$\Omega$	Recruitment rate
$\mu$	Natural mortality rate
$\beta$	Contact rate with infected birds
$\sigma$	Contact rate with contaminated environment
$\alpha$	Recovery rate from infection
$\omega$	Rate of mortality due to IBD
$\pi$	Rate of passive immunity loss

## 2.1 Assumptions

There are some assumptions made in developing the model:

- (1) The population is not fixed.
- (2) Birds get into the system by birth or immigration.
- (3) Chickens bellow two weeks old are protected by passive immunity from their mothers.
- (4) The population is mixed homogeneously (have the same interaction rate with one another).
- (5) Non-negative parameter are used.

## 2.2 Positivity of the solution

In this section, we prove that the variables remain positive for they stand for living population. Assuming that the initial condition of the model is non-negative, we show that the solution of the model is positive.

**Theorem 2.1.** *Let  $\Lambda = \{(M, S, I, R) \in \mathbb{R}_+^4 : M_0 > 0, S_0 > 0, I_0 > 0, R_0 > 0\}$ .*

*Then the solution of  $\{M, S, I, R\}$  is positive for  $t \geq 0$ .*

**Proof**

From the system of differential equations (2.1), we have;

$$\frac{dM}{dt} \geq -(\pi + \mu M), \tag{2.2}$$

$$\frac{dS}{dt} \geq -(\beta I + \sigma + \mu)S. \tag{2.3}$$

$$\frac{dI}{dt} \geq -(\mu + \omega + \alpha)I. \tag{2.4}$$

$$\frac{dR}{dt} \geq -\mu R, \tag{2.5}$$

Integrating both sides of inequality (2.2),(2.3), (2.4), (2.5) and simplifying the equations we obtain;

$$\begin{aligned} M(t) &\geq Ae^{-(\pi+\mu)t}, \\ S(t) &\geq Ae^{-(\beta I+\sigma+\mu)t}, \\ I(t) &\geq Ae^{-(\mu+\omega+\alpha)t}, \\ R(t) &\geq Ae^{-\mu t}. \end{aligned}$$

When we substitute the initial condition when  $t = 0$  and simplify we finally obtain;

$$(\pi + \mu) > 0, (\beta I + \sigma + \mu) > 0, (\mu + \omega + \alpha) > 0, \mu > 0.$$

Since all the model solutions are positive, this is the completes proof of the theorem.

### 2.3 Invariant region

**Theorem 2.2.** *The closed region  $\Lambda$  is positively invariant attracting all solutions.*

**Proof** We obtain the invariant region, in which the solution is bounded. Considering the total population ( $N$ ), where;

$$N = M + S + I + R. \tag{2.6}$$

Differentiating  $N$  both sides with respect to ( $t$ ) we get;

$$\frac{dN}{dt} = \frac{dM}{dt} + \frac{dS}{dt} + \frac{dI}{dt} + \frac{dR}{dt}. \tag{2.7}$$

$$\frac{dN}{dt} \leq \Omega - \mu N. \tag{2.8}$$

Integrating both sides of (2.8) and simplifying we get

$$\Omega - \mu N \geq Ae^{-\mu t}. \tag{2.9}$$

By applying the initial conditions;  $t = 0, N(0) = N_0$ , in (2.9),

$$A \leq \Omega - \mu N_0, \tag{2.10}$$

putting (2.10) into (2.9) we obtain,

$$N \leq \frac{\Omega}{\mu} - \left( \frac{\Omega - \mu N_0}{\mu} \right) e^{-\mu t}. \tag{2.11}$$

As  $t \rightarrow \infty$  in (2.11), the population size;

$$N \rightarrow \frac{\Omega}{\mu}, \tag{2.12}$$

which implies that,

$$0 \leq N \leq \frac{\Omega}{\mu}.$$

Since the study represents living flock of birds population, all state variables remains positive all the time. The solution set which is feasible invariant is given by;

$$\Lambda = \left\{ (M, S, I, R) \in \mathbb{R}_+^4 : 0 \leq M + S + I + R \leq \frac{\Omega}{\mu} \right\}. \tag{2.13}$$

Hence  $\Lambda$  is a positive invariant region.

### 2.4 Disease free equilibrium (DFE)

To find the disease free equilibrium of IBD ,we set the system of equation (2.1) to zero. At this state , there are no infection and recovery, that is  $I = R = 0$ . Thus,

$$\begin{aligned} \Omega - (\pi + \mu)M &= 0, \\ \pi M - \beta(0)S - (\sigma + \mu)S &= 0, \\ \beta(0)S + \sigma S - (\mu + \omega + \alpha)(0) &= 0, \\ \alpha(0) - \mu(0) &= 0. \end{aligned} \tag{2.14}$$

From first equation of (2.14) we get;

$$M^* = \frac{\Omega}{(\pi + \mu)}.$$

And from the second equation of (2.14), we get

$$S^* = \frac{\pi M^*}{(\sigma + \mu)},$$

where  $S^*$  is given by;

$$S^* = \frac{\pi\Omega}{(\sigma + \mu)(\pi + \mu)}.$$

And

$$I^* = R^* = 0.$$

Thus the DFE ,

$$E_0^*(M^*, S^*, I^*, R^*) = \left( \frac{\Omega}{(\pi + \mu)}, \frac{\pi\Omega}{(\sigma + \mu)(\pi + \mu)}, 0, 0 \right). \quad (2.15)$$

## 2.5 Basic reproduction number ( $R_0$ )

Basic reproductive number is used to show whether an infectious disease can die or continue spreading in the population. The value of  $R_0$  during an out break is urgently estimated and its value provide insight when designing control measures for the disease.

We use next generation matrix (NGM) approach to determine  $R_0$ . From NGM we have

$$G = FV^{-1}.$$

Where  $F$  is the Jacobian of  $f_i$  and is the rate of new infections in compartment I.

$V$  is the Jacobian matrix of  $v_i$ , where  $v_i$  is the rate of transfer of infections from one compartment to another

The model equation with new ineffective class is;

$$\frac{dI}{dt} = \beta IS + \sigma S - (\mu + \omega + \alpha)I.$$

The associated matrices from the model are:

$$f_i = \beta IS + \sigma S,$$

$$F = \frac{\partial f_i}{\partial I} = \beta S.$$

From DFE,  $S = \frac{\pi\Omega}{(\pi + \mu)(\sigma + \mu)}$ ,  
therefore;

$$F = \frac{\beta\pi\Omega}{(\pi + \mu)(\sigma + \mu)}. \quad (2.16)$$

Then

$$v_i = v_i^- - v_i^+,$$

$$v_i^- = (\mu + \omega + \alpha)I, \text{ while } v_i^+ = 0$$

therefore,

$$v_i = (\mu + \omega + \alpha)I,$$

$$V = \frac{\partial v_i}{\partial I} = (\mu + \omega + \alpha).$$

On computing

$$V^{-1} = \frac{1}{(\mu + \omega + \alpha)}. \quad (2.17)$$

Thus

$$FV^{-1} = \frac{\beta\pi\Omega}{(\pi + \mu)(\sigma + \mu)(\mu + \omega + \alpha)}.$$

The basic reproductive number  $R_0$  is the spectral radius of the matrix  $FV^{-1}$  which is given by;

$$\rho(FV^{-1}) = \frac{\beta\pi\Omega}{(\pi + \mu)(\sigma + \mu)(\mu + \omega + \alpha)}.$$

Therefore

$$R_0 = \frac{\beta\pi\Omega}{(\pi + \mu)(\sigma + \mu)(\mu + \omega + \alpha)}. \quad (2.18)$$

## 2.6 Stability of the disease - free equilibrium

### 2.6.1 Local stability

**Theorem 2.3.** *The disease free equilibrium is locally asymptotically stable when all the eigenvalues have a negative real part for  $0 \leq t < \infty$ . [11]*

**Proof:**

This theorem is proven by first obtaining the Jacobian matrix of the model system at DFE ( $E_0$ ) as follows;

Let

$$\begin{aligned} X_1 &= \Omega - (\pi + \mu)M, \\ X_2 &= \pi M - (\mu + \beta I + \sigma)S, \\ X_3 &= \beta IS + \sigma S - (\mu + \omega + \alpha)I, \\ X_4 &= \alpha I - \mu R. \end{aligned} \quad (2.19)$$

$$J(M, S, I, R) = \begin{pmatrix} \frac{\partial X_1}{\partial M} & \frac{\partial X_1}{\partial S} & \frac{\partial X_1}{\partial I} & \frac{\partial X_1}{\partial R} \\ \frac{\partial X_2}{\partial M} & \frac{\partial X_2}{\partial S} & \frac{\partial X_2}{\partial I} & \frac{\partial X_2}{\partial R} \\ \frac{\partial X_3}{\partial M} & \frac{\partial X_3}{\partial S} & \frac{\partial X_3}{\partial I} & \frac{\partial X_3}{\partial R} \\ \frac{\partial X_4}{\partial M} & \frac{\partial X_4}{\partial S} & \frac{\partial X_4}{\partial I} & \frac{\partial X_4}{\partial R} \end{pmatrix}.$$

$$J(M, S, I, R) = \begin{pmatrix} -(\pi + \mu) & 0 & 0 & 0 \\ \pi & -(\mu + \beta I + \sigma) & -\beta S & 0 \\ 0 & \beta I + \sigma & \beta S - (\mu + \omega + \alpha) & 0 \\ 0 & 0 & \alpha & -\mu \end{pmatrix}.$$

The Jacobian matrix at disease free equilibrium is given by the relation;

$$E_0^*(M^*, S^*, I^*, R^*) = \left( \frac{\Omega}{\mu + \pi}, \frac{\Omega\pi}{(\mu + \pi)(\mu + \sigma)}, 0, 0 \right).$$

$$J_0 = \begin{pmatrix} -(\pi + \mu) & 0 & 0 & 0 \\ \pi & -(\mu + \sigma) & \frac{\beta\Omega\pi}{(\mu + \pi)(\mu + \sigma)} & 0 \\ 0 & \sigma & \frac{\beta\Omega\pi}{(\mu + \pi)(\mu + \sigma)} - (\mu + \omega + \alpha) & 0 \\ 0 & 0 & \alpha & -\mu \end{pmatrix}.$$

To simplify our work we let ;

$$A = -(\pi + \mu),$$

$$B = -(\mu + \sigma) = B,$$

$$C = \frac{\beta\Omega\pi}{(\mu + \pi)(\mu + \sigma)} - (\mu + \omega + \alpha).$$

So the  $J_0$  matrix becomes;

$$J_0 = \begin{pmatrix} A & 0 & 0 & 0 \\ \pi & B & \frac{\beta\Omega\pi}{(\mu + \pi)(\mu + \sigma)} & 0 \\ 0 & \sigma & C & 0 \\ 0 & 0 & \alpha & -\mu \end{pmatrix}.$$

Solving for the eigenvalues which is represented by  $\lambda$  from the matrix;

$$|J_0 - \lambda I| = \begin{vmatrix} A - \lambda & 0 & 0 & 0 \\ \pi & B - \lambda & \frac{\beta\Omega\pi}{(\mu + \pi)(\mu + \sigma)} & 0 \\ 0 & \sigma & C - \lambda & 0 \\ 0 & 0 & \alpha & -\mu - \lambda \end{vmatrix} = 0,$$

We have;

$$(A - \lambda)(B - \lambda)((C - \lambda)(-\mu - \lambda)) = 0. \tag{2.20}$$

On evaluating equation (2.20) we have the eigenvalues as;

$$\lambda_1 = -(\pi + \mu),$$

$$\lambda_2 = -(\mu + \sigma),$$

$$\lambda_3 = \frac{\beta\Omega\pi}{(\mu + \pi)(\mu + \sigma)} - (\mu + \omega + \alpha),$$

$$\lambda_4 = -\mu. \tag{2.21}$$

For the DFE to be asymptotically stable, we require  $\lambda_3 < 0$ .

This means that;

$$\left( \frac{(\beta\Omega\pi)(\mu + \omega + \alpha)}{(\pi + \mu)(\sigma + \mu)(\mu + \omega + \alpha)} - (\mu + \omega + \alpha) \right) < 0.$$

But from equation (2.18) we have,

$$R_0 = \left( \frac{\beta\Omega\pi}{(\pi + \mu)(\sigma + \mu)(\mu + \omega + \alpha)} \right).$$

Therefore we have;

$$R_0(\mu + \omega + \alpha) - (\mu + \omega + \alpha) < 0. \tag{2.22}$$



This means that

$$R_0(\mu + \omega + \alpha) < (\mu + \omega + \alpha). \tag{2.23}$$

or

$$R_0 < 1. \tag{2.24}$$

We note that  $R_0 < 1$  regardless of the value of our parameters at the DFE. Thus in this section, since we have shown that  $R_0 < 1$ , the DFE is locally asymptotically stable and this completes the proof.

From equation (2.18) of  $R_0$  making  $\sigma$  the subject we have;

$$R_0 = \frac{\beta\Omega\pi}{(\pi + \mu)(\sigma + \mu)(\omega + \alpha + \mu)}.$$

Therefore we have,

$$\sigma > \frac{\beta\Omega\pi - \mu(\pi + \mu)(\omega + \alpha + \mu)}{(\pi + \mu)(\omega + \alpha + \mu)}. \tag{2.25}$$

**Theorem 2.4.** *In the system (2.1), we have  $R_0 < 1$  if and only if*

$$\sigma > \frac{\beta\Omega\pi - \mu(\pi + \mu)(\omega + \alpha + \mu)}{(\pi + \mu)(\omega + \alpha + \mu)},$$

*hence, the DFE of the system will be locally asymptotically stable.*

### 2.6.2 Global stability

Considering the approach by Castillo-Chaven theorem [12], the model system of model equation is expressed as;

$$\begin{aligned} \frac{dP}{dt} &= W(P, Q) \\ \frac{dQ}{dt} &= G(P, Q), G(P, 0) = 0 \end{aligned}$$

where  $P = (M(t), S(t))$  and  $Q = (I(t))$ , with components of  $P \in R^2$  representing infected population, while  $Q \in R$  represents infected population. And  $E_0^* = (P^*, 0)$  denotes the disease free equilibrium of the model.

Conditions for global stability:

A1.  $\frac{dP}{dt} = W(P, 0)$ ,  $P^*$  is GAS

A2.  $G(P, Q) = A Q - \bar{G}(P, Q)$ ,  $\bar{G}(P, Q) \geq 0$  for  $(P, Q) \in \Gamma$

Where  $A = D_q G(P, Q)$  is an M-matrix, where off diagonal element of A are non-negative, and  $\Gamma$  is the region where the model makes biological sense.

If the model system satisfies the conditions above according to Castillo-Chaven, then the following theorem holds.

**Theorem 2.5.** *The equilibrium point  $E_0^* = (P^*, 0)$  of the model system (3.1) is globally asymptotically stable provided  $R_0 < 1$  (locally asymptotically stable) and condition A1 and A2 are satisfied [12]*

**Proof:**

From the model system we have;

$$P = (M, S), Q = (I(t))$$

$$W(P, Q) = \begin{pmatrix} \Omega - (\pi + \mu)M \\ \pi M - \beta IS - (\sigma + \mu)S \end{pmatrix}, G(P, Q) = \begin{pmatrix} \beta IS + \sigma S - (\mu + \omega + \alpha)I \\ 0 \end{pmatrix} \text{ and } P^* = (M^*, S^*, 0, 0)$$

$$\frac{dP}{dt} = W(P, 0) = \begin{pmatrix} \Omega - (\pi + \mu)M \\ \pi M - (\sigma + \mu)S \end{pmatrix}$$

Which shows that  $P^* = (M^*, S^*, 0, 0)$  is globally asymptotically stable; hence condition A1 is satisfied.

For condition A2 we have ,

$$A = D_q G(P^*, 0) = \begin{pmatrix} \beta S - (\mu + \omega + \alpha) & 0 \\ 0 & 0 \end{pmatrix}$$

and

$$\bar{G}(P, Q) = \begin{pmatrix} \beta IS + \sigma S \\ 0 \end{pmatrix} = \begin{pmatrix} \beta I(S^* - S) + \sigma(S^* - S) \\ 0 \end{pmatrix}$$

Since  $S^* > S$ , this clearly shows that  $\bar{G}(P, Q) \geq 0$ .

Therefore condition (A2) is satisfied. Hence the disease free equilibrium of the system is globally asymptotically stable (G.A.S) when  $R_0 < 1$ .

## 2.7 Endemic equilibrium (EE)

This is a steady state solution that shows that the disease does not die in the population.

Let  $E_1^* = (M^*, S^*, I^*, R^*)$  be the endemic point, where  $M^*, S^*, I^*, R^* > 0$

Setting the system of equation (2.1) to zero and evaluating the state variables, the endemic equilibrium points would be as follows:

$$\frac{dM}{dt} + \frac{dS}{dt} + \frac{dI}{dt} + \frac{dR}{dt} = 0,$$

;

$$0 = \Omega - (\pi + \mu)M^*, \tag{2.26}$$

$$0 = \pi M^* - \beta I^* S^* - (\sigma + \mu)S^*, \tag{2.27}$$

$$0 = \beta I^* S^* + \sigma S^* - (\omega + \alpha + \mu)I^*, \tag{2.28}$$

$$0 = \alpha I^* - \mu R^*. \tag{2.29}$$

From (2.26) we get;

$$M^* = \frac{\Omega}{\pi + \mu}. \tag{2.30}$$

Using (2.29) we get;

$$R^* = \frac{\alpha}{\mu} I^*. \tag{2.31}$$

Putting (2.30) into (2.27) we get;

$$S^* = \frac{\Omega \pi}{(\pi + \mu)(\beta I^* + \sigma + \mu)}. \tag{2.32}$$

Substituting the value of  $S^*$  into (2.28) and simplifying, we obtain a characteristic equation;

$$A(I^*)^2 + B(I^*) + C = 0. \tag{2.33}$$

Where

$$\begin{aligned} A &= \beta(\pi + \mu)(\mu + \omega + \alpha), \\ B &= -\beta\Omega\pi + (\sigma + \mu)(\pi + \mu)(\mu + \omega + \alpha), \\ C &= -\Omega\pi\sigma. \end{aligned}$$

On substituting (2.18) in B,  $R_0 = \frac{\beta\pi\Omega}{(\pi+\mu)(\sigma+\mu)(\mu+\omega+\alpha)}$ , we have therefore have:

$$\begin{aligned} A &= \beta(\mu + \pi)(\omega + \alpha + \mu), \\ B &= -(\sigma + \mu)(\pi + \mu)(\omega + \alpha + \mu)(1 - R_0), \\ C &= -\Omega\pi\sigma. \end{aligned}$$

The endemic equilibrium point  $M^*$  given in the equilibrium point is positive since all the parameters are positive. While  $S^*$  and  $R^*$  are in terms of  $I^*$ . On substituting the positive value of  $I^*$ , we will have them being positive. We obtained  $I^*$  by solving the quadratic equation (2.33).

### 2.7.1 Stability of endemic equilibrium

The endemic equilibrium point of the model  $E_1^* = (M^*, S^*, I^*, R^*)$  where,

$$\begin{aligned} M^* &= \frac{\Omega}{\pi + \mu}, \\ S^* &= \frac{\Omega\pi}{(\pi + \mu)(\beta I^* + \sigma + \mu)}, \\ I^* &= \frac{-(1 - R_0) + \sqrt{(1 - R_0)^2 + 4\frac{\sigma}{\sigma + \mu}R_0}}{2\left(\frac{\beta}{\sigma + \mu}\right)}, \\ R^* &= \frac{\alpha I^*}{\mu}. \end{aligned} \tag{2.34}$$

We find that the stability of endemic equilibrium is locally asymptotically stable, if by finding the eigenvalues they have negative real parts.

Using the Jacobian matrix obtained from the model equation at the EE point (2.34), we have;

$$J_{(E_1^*)} = \begin{pmatrix} -J_{11} & 0 & 0 & 0 \\ J_{21} & -J_{22} & -J_{23} & 0 \\ 0 & J_{32} & J_{33} & 0 \\ 0 & 0 & J_{43} & -J_{44} \end{pmatrix}.$$

Where

$$J_{11} = (\pi + \mu), J_{22} = (\mu + \beta I^* + \sigma), J_{32} = \beta I^* + \sigma, J_{33} = \beta S^* - (\mu + \omega + \alpha), J_{23} = \beta S^*, J_{21} = \pi, J_{43} = \alpha, J_{44} = \mu.$$

On evaluating the Jacobian matrix  $J_{(E_1^*)}$ , we obtain the eigenvalues  $\lambda_1 = -(\pi + \mu)$ ,  $\lambda_4 = -\mu$  and the characteristic equation can also be expressed as;

$$a_0\lambda^2 + a_1\lambda + a_2. \tag{2.35}$$

Where

$$\begin{aligned} a_0 &= 1, \\ a_1 &= (J_{22} - J_{33}), \\ a_2 &= (J_{23}J_{32} - J_{22}J_{33}). \end{aligned} \tag{2.36}$$

**Theorem 2.6.** *For endemic equilibrium of model system (2.1) to be stable, we need to have the coefficients of the characteristic equation (2.35), being positive. Otherwise it will be unstable.*

The necessary conditions for stability are:

- C1. The coefficients of the characteristic equation should be positive and real.

$$a_i > 0, i = 0, 1, 2, 3.$$

- C2. The coefficients of the characteristic equation should be non-zero.

**Proof**

Condition C2, is fulfilled since the coefficients of equation (2.35) are non-zero as shown in (2.36).

For C1 to be fulfilled, we need to set the following conditions of inequalities for  $a_1 > 0$  and  $a_2 > 0$ . On simplifying the inequalities in equation (2.36), we obtain;

$$a_0 = 1 > 0. \tag{2.37}$$

$$a_1 = \beta(I^* - S^*) + (2\mu + \omega + \sigma + \alpha) > 0. \tag{2.38}$$

$$a_2 = (\beta I^* + \sigma)(\omega + \alpha) > 0. \tag{2.39}$$

Since the coefficients of the characteristic equation (2.35) are all positive as in equation (2.37), (2.38) and (2.39), this implies that the endemic equilibrium of the system (2.1) is locally and globally stable when  $R_0 < 1$ , hence the proof.

### 3 Numerical Results

We carried out simulations of model system (2.1) using MATLAB, to investigate the effect contaminated environment had on the transmission dynamics of IBD. This was achieved by use of the initial values on the tables 3 and parameter values which were all assumed.

**Table 3. Variables used in the simulations**

Variables	value
M(0)	800
S(0)	600
I (0)	150
R(0)	10

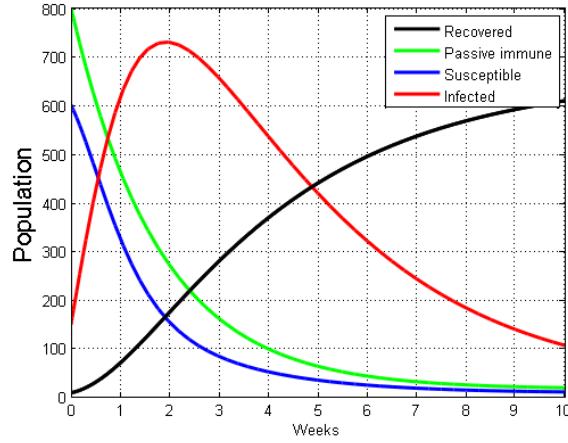

**Fig. 2.** We have used the following parameters in the simulation of the model system M,S,I,R of the total population when  $R_0 < 1$  :  $\Omega = 10, \mu = 0.001, \beta = 0.001, \sigma = 0.95, \alpha = 0.15, \omega = 0.225, \pi = 0.565, R_0 = 0.02792$ . A decrease in number of population in M and S class is observed as class I increases to its peak, then drops as time progresses. compartment R also increases at a constant rate

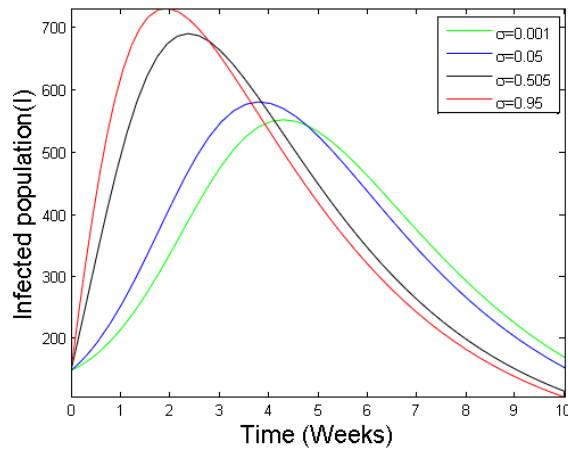

**Fig. 3.** The parameters used in the simulation of the infected population with varied contact rate with the environment, when  $R_0 < 1$  and when  $R_0 > 1$  are :  $\Omega = 10, \mu = 0.001, \beta = 0.001, \alpha = 0.15, \omega = 0.225, \pi = 0.565, \sigma = [0.001, 0.05, 0.505, 0.95]$ . High contact rate between the contaminated environment leads to high infection rate in the system, great number of flock get infected.

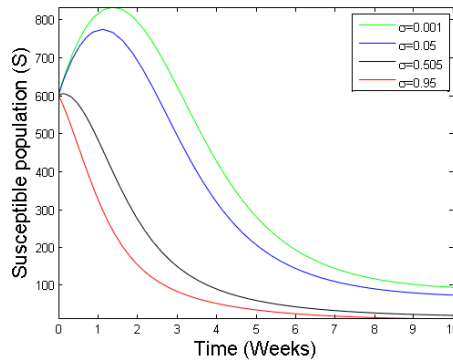

**Fig. 4.** The simulation of the susceptible population when the parameter  $\sigma$  representing contact rate with the environment is varied. The parameters used when  $R_0 < 1$  and when  $R_0 > 1$  are:  
 $\Omega = 10, \mu = 0.001, \beta = 0.001, \alpha = 0.15, \omega = 0.225, \pi = 0.565, \sigma = [0.001, 0.05, 0.505, 0.95]$ . **High contact rate between the susceptible flock and the contaminated environment leads to increase in infectious in the system hence the susceptible flock reduces in number.**

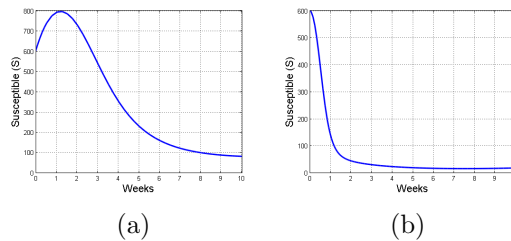

**Fig. 5.** Susceptible population when  $R_0 < 1$  and when  $R_0 > 1$ . In (a), the parameters used when  $R_0 = 0.8564$  are  $\beta = 0.001, \sigma = 0.03, \mu = 0.001, \omega = 0.225, \pi = 0.5655, \Omega = 10$ . The rate of infection is low when  $R_0 < 1$ . In (b), the parameters used when  $R_0 = 2.885$  are  $\beta = 0.005, \sigma = 0.045, \mu = 0.001, \omega = 0.225, \pi = 0.5655, \Omega = 10$ . The rate of infection is high and the population decreases drastically with time when  $R_0 > 1$

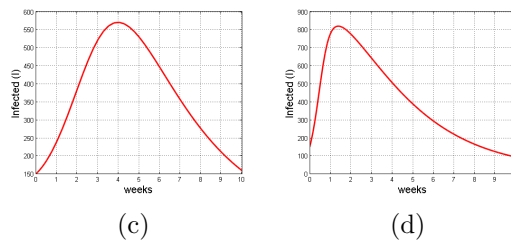

**Fig. 6.** The simulation of the infected population when  $R_0 < 1$  and when  $R_0 > 1$ . In (a), the parameters used when  $R_0 = 0.8564$  are:  
 $\beta = 0.001, \sigma = 0.03, \mu = 0.001, \omega = 0.225, \pi = 0.5655, \Omega = 10$ . The infection takes time to pick up and the trajectory move to zero along the x-axis when the system is stable. In (b), the parameters used when  $R_0 = 2.885$  are:  
 $\beta = 0.005, \sigma = 0.045, \mu = 0.001, \omega = 0.225, \pi = 0.5655, \Omega = 10$ . The infection pick up immediately and the trajectory does not reach the x-axis when the system is unstable

## 4 Discussion

A study carried out by Silke and Sharma, indicated that maternal acquired antibody alone are not adequate to protect chickens against IBDV and that introducing T-cell was critical for protection [13]. The finding done by Van den Berg and Meulemans, on Protection afforded by maternally derived antibodies and inference with live vaccination, on acute infection of bursal disease in poultry indicated that chicks are not fully protected against highly pathogenic strain of IBDV during there growing period by their maternally derived antibodies [14].

From Fig. 2, there is a decrease in Partially immune class (M) as birds lose their maternal antibody. They become susceptible to IBD infection, hence move into S-class. As the birds in susceptible compartment interact with contaminated environment, the chicken will be infected and move to infected class, where an increase in the population will be observed, since the birds can not be sufficiently protected by the maternal antibodies [1].

As the birds in susceptible class interact with the contaminated environment they are infected by the infectious bursal disease virus, since the virus is transmitted laterally by direct or indirect contact between the contaminated environment and susceptible [2]. In Fig. 3,5 and 6 as the contact rates varies, the rate of infections also changes. As the susceptible come into contact with the infected within the same environment, leads to increase in infection in the system [4, 5].

## 5 Conclusion

In this paper, we developed a four compartmental model of transmission dynamics of infectious bursal disease (M,S,I,R) taking into consideration the effect of environmental factors.

We derived the reproductive number  $R_0$ , which predicts the state of the infection in the system. The stability of the disease free equilibrium and endemic equilibrium was analysed and found it to be locally and globally asymptotically stable if  $R_0 < 1$  and unstable if  $R_0 > 1$ . For the system to be stable, we have;

$$\sigma > \frac{\beta\Omega\pi - \mu(\pi + \mu)(\omega + \alpha + \mu)}{(\pi + \mu)(\omega + \alpha + \mu)}$$

When the model is stable, it means the disease will die off with time and the spread of the epidemic can be controlled. But if  $R_0 > 1$  the model is unstable. The model exhibited the existence of unique endemic equilibrium points, as the value of  $I^*$  depended on  $R_0$ . Endemic equilibrium is stable when  $R_0 < 1$  and unstable when  $R_0 > 1$ . When  $R_0 < 1$  the disease takes time to pick up in the system and it reaches the peak after a longer time. When  $R_0 > 1$  the disease spreads much faster in the system and reaches the peak after a short time, but the trajectory does not return to zero.

From numerical simulations, it proves that the spread of IBD is highly enhanced by the interaction between the susceptible and contaminated environment. When the contact rate is high, most of the birds become infected with the virus within a short period.

## Acknowledgment

I acknowledge the support I received from Isaac Mwangi. My sincere gratitude also goes to the General Superior of my congregation Sr Mary Benigna Aoko for financing the research.

## Competing Interest

Authors have declared that no competing interest exists.

## References

- [1] Van den Berg TP, Eterradossi N, Toquin D, Meulemans G. Infectious bursal disease (Gumboro disease). *Revue scientifique et technique* (International Office of Epizootics). 2000;19(2):509-43.
- [2] Lasher HN, Shane S. Infectious bursal disease. *World's Poultry Science Journal*. 1994;50(2):133-66.
- [3] Boudaoud A, Mamache B, Tombari W, Ghram A. Virus mutations and their impact on vaccination against infectious bursal disease (Gumboro disease). *Rev Sci Tech*. 2016;35(3):875-97.
- [4] Teshome M, Fentahunand T, Admassu B. Infectious bursal disease (Gumboro disease) in Chickens. *British Journal of Poultry Sciences*. 2015;4(1):22-8.
- [5] Dey S, Pathak DC, Ramamurthy N, Maity HK, Chellappa MM. Infectious bursal disease virus in chickens: Prevalence, impact, and management strategies. *Veterinary Medicine: Research and Reports*. 2019;10:85.
- [6] Gary DB, Richard DM. Infectious bursal disease (Gumboro) in commercial broilers. IFAS Extension, University of Florida, VM84; 2008.
- [7] Mller H, Mundt E, Eterradossi N, Islam MR. Current status of vaccines against infectious bursal disease. *Avian Pathology*. 2012;41(2):133-9.
- [8] Snyder DB. Changes in the field status of infectious bursal disease virus; 1990.
- [9] Tadesse M, Dessie T. Milk production performance of Zebu, Holstein Friesian and their crosses in Ethiopia. *Livestock research for rural development*. 2003;15(3):1-9.
- [10] Ghorashi SA, ORourke D, Ignjatovic J, Noormohammadi AH. Differentiation of infectious bursal disease virus strains using real-time RT-PCR and high resolution melt curve analysis. *Journal of virological methods*. 2011;171(1):264-71.
- [11] Roussel MR. Stability analysis for ODEs. *Nonlinear Dynamics, lecture notes*, University Hall, Canada; 2005.
- [12] Castillo-Chavez C, Blower S, Van den Driessche P, Kirschner D, Yakubu AA, editors. *Mathematical approaches for emerging and reemerging infectious diseases: An introduction*. Springer Science & Business Media; 2002.
- [13] Rautenschlein S, Yeh HY, Sharma JM. The role of T cells in protection by an inactivated infectious bursal disease virus vaccine. *Veterinary Immunology and Immunopathology*. 2002;89(3-4):159-167.
- [14] Van den Berg TP, Meulemans G. Acute infectious bursal disease in poultry: Protection afforded by maternally derived antibodies and interference with live vaccination. *Avian pathology*. 1991;20(3):409-421.

---

© 2020 Omollo and Kimathi; This is an Open Access article distributed under the terms of the Creative Commons Attribution License <http://creativecommons.org/licenses/by/4.0>, which permits unrestricted use, distribution, and reproduction in any medium, provided the original work is properly cited.

**Peer-review history:**

The peer review history for this paper can be accessed here (Please copy paste the total link in your browser address bar)

<http://www.sdiarticle4.com/review-history/59641>