



# Hybrid Neuro-Fuzzy Based Improved Control Design of Electro-Pneumatic Clutch Actuation Control System for Heavy Duty Vehicles

**Ndubuisi, Paul-Darlington Ibemezie <sup>a</sup>, Nwoke Obinna <sup>b</sup>,  
Julius Egwu Arua <sup>b\*</sup>, Babalola Adegboyega Dare <sup>b</sup>,  
Anunwa Anthony Alexander <sup>c</sup>, Bassey, Kenneth Akpan <sup>c</sup>  
and Igwe Lazarus Uduma <sup>d</sup>**

<sup>a</sup> Rectory Division Federal Polytechnic, Ngodo-Isuochi, Abia State, Nigeria.

<sup>b</sup> Department of Mechatronics Engineering Technology, Akanu Ibiam Federal Polytechnic, Unwana, Ebonyi State, Nigeria.

<sup>c</sup> Department of Electrical Electronics Engineering Technology, Akanu Ibiam Federal Polytechnic, Unwana, Ebonyi State, Nigeria.

<sup>d</sup> Department of Mechanical Engineering Technology, Akanu Ibiam Federal Polytechnic, Unwana, Ebonyi State, Nigeria.

## **Authors' contributions**

*This work was carried out in collaboration among all authors. All authors read and approved the final manuscript.*

## **Article Information**

DOI: <https://doi.org/10.9734/jerr/2024/v26i101299>

### **Open Peer Review History:**

This journal follows the Advanced Open Peer Review policy. Identity of the Reviewers, Editor(s) and additional Reviewers, peer review comments, different versions of the manuscript, comments of the editors, etc are available here: <https://www.sdiarticle5.com/review-history/124244>

**Original Research Article**

**Received: 01/08/2024**

**Accepted: 03/10/2024**

**Published: 08/10/2024**

\*Corresponding author: Email: [jeaaru@akanuibiampoly.edu.ng](mailto:jeaaru@akanuibiampoly.edu.ng);

## ABSTRACT

The application of hybrid Neuro-Fuzzy principles of clutch actuation control in enhancing the performance of electro-pneumatic clutch actuation system for heavy duty vehicles is the aim of this presentation. Neuro-Fuzzy is a hybrid design that accommodates the principles of fuzzy Logic and Neural Network in a manner that take advantage of their positive sides. The inability of some heavy-duty vehicles to operate optimally on hilly terrains and which often results in road mishaps are traceable to the inadequacies in conventional clutch actuation control mechanisms. These conventional actuation control techniques provide for routine calibration of clutch actuators after maintenance. Often times, this important requirement of calibration is neglected with attendant ugly consequences. To stem this tide of manual calibration and its obvious defects, an intelligent method of clutch actuation modelled in a hybrid Neuro-Fuzzy control is implemented. Conventional data obtained for errors, speed, torque and power from Mercedes Benz Actros Truck model MP 2, 2031 provided the reference points. These data were embedded into a Simulink block and cascaded into a designed Neuro-Fuzzy Simulink model. Both conventional and Neuro-Fuzzy Simulink model controllers were also simulated. Different percentages of improvements were recorded for piston error, angular speed, engine torque and power respectively. The level and percentage of improvements stood at 0.4821mm or 33.04% decrease for error, increases of 334.1 RPM or 33% for angular speed, 0.0594NM or 33.26% for torque and 2.79W or 16.53% for power respectively.

*Keywords: Artificial neural network; actuation; control; calibration; transmission.*

## 1. INTRODUCTION

The need of heavy-duty vehicles in our environments for transportation purposes cannot be over emphasized. The ability of the vehicles to initiate movements and hence accomplish a given assignment is by virtue of the ability of the motor vehicle to achieve rotary motions or torque. The requirements for engine torque differ for different work needs. The different work needs provided the justification for mechanical amplifications. Gearing mechanisms are used to achieve this purpose. Smooth mechanical amplifications or transitions between several gearing positions would have been impossible without a clutch actuation system. A clutch actuation mechanism acts as an isolator between the drive shaft linked to the engine and the driven shaft connected to the load or wheels of motor vehicles. The clutch safeguards the gear system from teeth grinding during the transition periods. The effectiveness and smoothness of the coupling of the drive and driven shafts during the gearing transition or amplification is an indication of perfect match in clutch mechanism and power transmission between the engine and the load. The gear shift quality of a vehicle is a measure for accessing how good a clutch system is [1]. The processes in clutching mechanism cannot be smooth without control system mechanisms. It is through control process that the clutch activates instruction to the automobile or machine to move or stop. A clutch is a device applied to engage

and disengage transmission of power particularly from a driving shaft to a driven shaft. It can also be said that a clutch ensures that the transmission link between the engine and the driven parts establishes a releasable torque [2]. Clutches like brakes are ideally control elements for proper control and smooth transmission of drive torque, power and speed in many rotating drive systems. The position of the piston in the actuator chamber is indicative of the amount of torque that a clutch system can transmit [3].

Any physical process that requires mechanical movement, linear or rotary must be subjected to a transformation or actuation process. Actuation process is thus a mechanical transformation system that uses its outputs to achieve a control action on a machine or device, with the ultimate aim of converting a linear motion to rotary motion or vice versa. A device or element deployed for this purpose is an actuator [4]. Enhancement in clutch actuation controls is critical for automobile developments. The present conventional control methods in the electrical control unit, appear inadequate owing to observed failures of heavy-duty vehicles on the roads especially on hilly terrains [5]. Some of the problems associated with clutch system in heavy-duty vehicles include; clutch wearing/burnt, torsional spring weakening, clutch vibrations, fibre rebating, and leakage in seals [6]. Friction forces, weakening piston springs and weakening of clutch release bearing are also included. There are also problems related to clutch diaphragm weakening

and clutch sticking. Samson [7] disclosed that wears are often seen in gear-based travel sensors. Clutch defects manifest in clutch actuation positional errors in actuation chambers with resultant effects on poor clutch engagement and disengagement.

Conventional control designs are in the forms of; off/on control, proportional control, servo mechanism control, integral control, and a combination of Proportional and Integral (PI) control. These designs accommodate in its clutch actuation control, the provision for frequent calibration of clutch load as a means of correcting inherent actuation problems to ensure better operation. Calibrations of clutch actuators are provided for during installations and routine maintenance operations [8]. Calibration also ensures quicker responsiveness of the actuator control as well as manoeuvring driving situations in slick roads and launching on hilly terrain with heavy loads among others [9]. Workshop Tips on Clutch from ZF Aftermarket on the topic Overview of all Workshop Tips on Clutches and repair Tips for Clutch System [10] observed that inability to effect routine calibration manifests in problems within the clutch actuation. Clutch calibration adjustments can be achieved in several ways. Firstly, calibration can be realised by disengaging the output or load shaft for a reference engine or input shaft speed is met. Secondly, it can be approached by increasing the pressures on the actuator piston while monitoring the engine speed for a low torque transmission to the load shaft or wheels. The essence of calibration is for variation in the fill time for clutch engagement and disengagement routines. Calibration can also result from the narrowing of the clutch travel distance in the actuator or by increasing pressure on the piston through the variation of the energizing current in the electrical control module of the clutch system [1]. The practices of calibration are often neglected by the heavy-duty vehicle operators; a neglect that leads to tales of woes.

A dynamic process for self-adjustment of calibration is the way out of this malady. The process will checkmate the weakening piston springs and weakening of clutch release bearings and similar prominent calibration faults responsible for piston positional error in clutch actuation. An Artificial Neural Network (ANN) system of intelligent controller technique is advocated as a substitute for conventional controller for the dynamic process to handle this calibration problem and hence improve efficiency in heavy-duty vehicles.

## **2. THE CONCEPT OF NEURO-FUZZY SYSTEM**

A hybrid model of fuzzy logic and neural network models is named neuro-fuzzy system. It is an artificial intelligent technique modelled as an infusion or a combination of a normal fuzzy logic and neural network. Discussions on fuzzy logic and neural network respectively indicates that if available knowledge can be expressed in linguistic rules, a fuzzy logic system or fuzzy inference system (FIS) can be built, and if data is available, or learning from a simulation or training is possible, then the use of artificial neural network is practicable. In order to construct a fuzzy inference (FIS), the fuzzy sets, the fuzzy operators and the knowledge base must be well defined. In a similarly way, the building of an artificial neural network for any given application requires that the structural set up and learning algorithm are needed to be specified too. Further observations and analysis by engineers' reveal that the limitations of the fuzzy logic and neural network approaches complement one another. It is therefore natural to speculate the idea of bringing them together in an integrated system to harness their combined advantages. Hence the learning capability advantage of the ANN and formation of linguistic rule base advantage of the fuzzy system can be fused together. The neuro-fuzzy hybrid model has ever remained efficient. Figs. 1 and 2 show two arrangements of the neuro-fuzzy intelligent agent system.

The swapping of fuzzy inference and neural network blocks in both models of neuro-fuzzy of Figs. 1 and 2 are significant. The term neuro-fuzzy is described generally as a type of artificial intelligent system with features and characteristics reminiscent of fuzzy logic and neural network models.

In a neuro-fuzzy model, neural network weights are adjusted by the fuzzy logic sets and rules. This weight adjustment is described as turning technique of the neural network. In the turning process, both the input and output data vector act on each other interactively while the weight adjustment or turning progresses until optimum output of zero error in between the network output and the desired output is realised. The neuro-fuzzy systems exhibit two unique and clear characteristic phases. They are the learning and the execution characteristic phases. The learning phase shows a behaviour that is characteristic of neural networks and assimilates

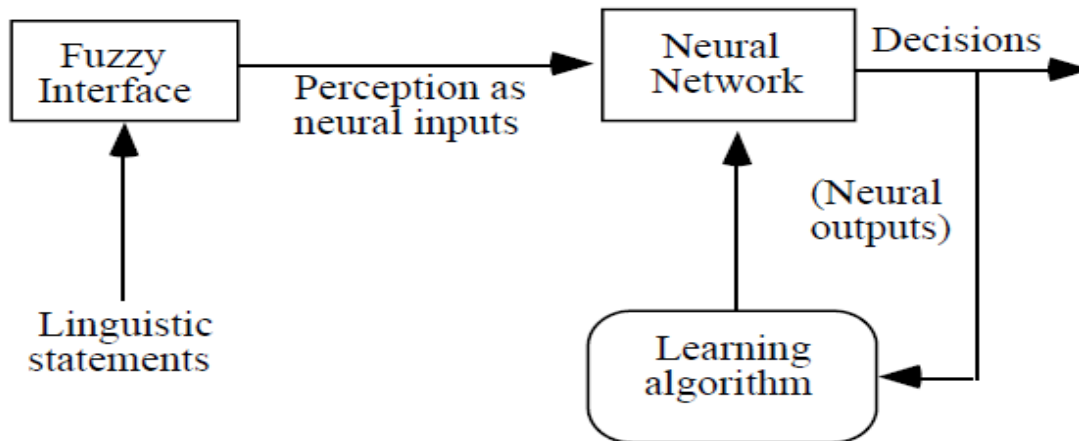

Fig. 1. First model of fuzzy neural system [11]

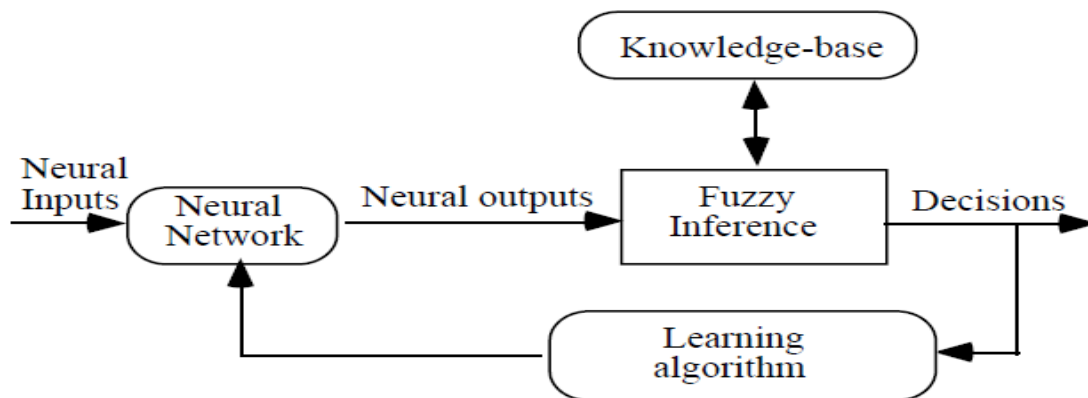

Fig. 2. Second model of fuzzy neural system [11]

or learns its own variables within and un-aided, while the execution phase of behaviour exhibits the fuzzy logic system character. Independently, either of the learning and the execution phases have merits and demerits. Therefore, combination of the two provides better results compared with the results recorded with the application of either of the isolated methods.

In control systems design, there is a greater need to tackle successfully the challenges brought about by increasing global competition in technology, environmental considerations, energy requirements, economy of materials and the demand for stable, robust and fault tolerant systems. A number of control system problems cannot be approached from the established conventional modelling techniques. The reason for this stems from the fact that conventional modelling techniques require precise, good knowledge of the system including the nonlinear response patterns. A complex control system

problem is characterised with high degree of uncertainty including time varying response characteristics. Systems that show evidence of these features cannot be adequately addressed with conventional modelling solutions. Hybrid neuro-fuzzy modelling solution approach has been discovered as a willing tool. It is a powerful model that ensures that information from empirical data sources and error-prone unclear model sources are effectively combined to solve problems. The neuro-fuzzy solution model utilises the fuzzy 'IF-THEN' rules described in a network structure and the neural network learning algorithms approach to provide solutions to a complex system [12]. The merging together of neural network and fuzzy logic are geared towards enhancing decision-making process in the provision of solutions to control systems. Neural network offers the tool for tuning the membership functions of a fuzzy logic system. The use of fuzzy logic rules expressed in linguistic terms can be applied in encoding

expert knowledge. This task consumes time in the design of fuzzy logic systems. In particular, defining the membership functions quantitatively from the linguistic expressions possess some challenges. The challenges can be mitigated by the introduction of the learning techniques of neural network model. This model can also be automated and thereby reduces to some extent; time and cost wasted in an effort to improve performance of a fuzzy system.

## **2.1 Interplay of Roles in Neuro-Fuzzy Applications**

In theory generally, fuzzy logic and neural networks systems share some similarities. These similarities explain why both are convertible. However, there are some differences that exist between them and accounts for the advantages and disadvantages in their applications for practical purposes. Specifically, while making decisions using imprecise data analysis and fuzzy logic, ANN is used to integrate human thinking processes in solving problems without modelling them mathematically. Thus, in contrast with Fuzzy logic, ANN applies the model of thinking found only in the human brain to solve a given problem. In neural network systems, back propagation algorithm technique enables knowledge acquisition automation to be possible. The only impediment is the comparative slow learning process and the difficulty in the analysis of the trained neural network or the black box system. Extraction of the rules or the structural knowledge frame work of the neural network black box from the trained neural network system is indeed challenging. It is a challenge too to integrate special information into the task being solved in a neural network in a way to upgrade the learning process. In these circumstances, fuzzy logic systems are the favourable option. Fuzzy logic system behaviour can be easily explained from the fuzzy rules and hence performance can be adjusted to meet target by effecting some changes in the fuzzy rules. The major interest in fuzzy logic design is the number of input variables and process of establishing its membership functions.

## **2.2 Advantages and disadvantages of Fuzzy Logic**

These few challenges of fuzzy logic system put a limit in its application to only areas with small

number of input variable requirements and where availability of expert knowledge is feasible.

Neural network systems provide solutions to knowledge acquisition challenges of fuzzy logic. They are capable of eliciting fuzzy rules automatically from numerical data. This explains the importance of cooperative approaches in the application of neural networks as a tool in the optimization of fuzzy system parameters. Neural network can also be applied in pre-processing data or information from which fuzzy control rules can be deduced [11]. Neuro-fuzzy modelling technique can be likened to a grey box or mask that lacks clarity but is imbedded within the boundary of neural networks and qualitative fuzzy models. The building blocks of neuro-fuzzy models are based on merging of algorithms used in the fields of neural networks, pattern recognition and regression analysis. The fundamental theory in artificial intelligence to which fuzzy logic and neural network systems are included arose from the thought of a possible imitation of man's ability to reason. The reasoning in fuzzy system expression indicates a seeming natural symbolic occurrence in an if-then rules. Similarly, in neural networks, the rule or network parameters are not stated explicitly. The working method is subsumed in a coded black box form. The neural network application model contrasts with a knowledge-based principle. Thus, no clear knowledge pattern is needed in neural network application. A hybrid neuro-fuzzy systems provide solutions to a task by the successful combination of the symbolic natural expression of 'IF THEN' rule of fuzzy systems and the learning ability of neural networks [12]. In the computation involving fuzzy system with multiple inputs, fuzzy logic structure can be presented as network structure displayed in like manner as to a neural network of the radial basis function (RBF) model. Similarly, fuzzy logic system's optimization of parameter process can take the form of gradient descent training algorithms that are usually applied in the area of neural networks computation. The gradient descent training algorithms approach is in most circumstances nicknamed neuro-fuzzy model [12]. The Author gave an illustration as shown in Fig. 3.

The Fig. 3 is a typical example of a zero-order Takagi-Sugeno (TS) fuzzy model. The resulting 'IF THEN' rules are presented here.

If  $x_1$  is  $A_{11}$  and  $x_2$  is  $A_{21}$  then  $y = b_1$  and If  $x_1$  is  $A_{12}$  and  $x_2$  is  $A_{22}$  then  $y = b_2$

It shows a TS fuzzy model with two rules indicated as in a neuro-fuzzy model. The nodes  $A_{11}$ ,  $A_{12}$ ,  $A_{21}$  and  $A_{22}$  are the result of the first layer membership functions of the input signals  $x_1$  and  $x_2$  of the fuzzy sets. The second node  $\beta_1$  and  $\beta_2$  indicates the product of the fuzzy sets with an 'and' linkage as shown in the rules. The third node is a normalizer node 'N' with  $b_1$  and  $b_2$  and represents the normalised outputs

respectively. The output 'y' is the summation accomplished by the fuzzy mean operator. This system model can be referred to as Adaptive Neuro-Fuzzy Inference System (ANFIS). The first-order TS fuzzy model can also be represented in a similar fashion. Again, consider the example with two rules: If  $x_1$  is  $A_{11}$  and  $x_2$  is  $A_{21}$  then  $y_1 = a_{11}x_1 + a_{12}x_2 + b_1$ .

If  $x_1$  is  $A_{12}$  and  $x_2$  is  $A_{22}$  then  $y_2 = a_{21}x_1 + a_{22}x_2 + b_2$  for which the corresponding network is given in Fig. 4.

**List 1. Advantages and disadvantages of Fuzzy Logic**

S/N	Advantages	Disadvantages
1.	Fuzzy logic is easy to code and understand	It is hard to use it to decide value judgement.
2.	It has wide industrial and practical applications	Knowledge acquisition in fuzzy logic system is somehow difficult.
3.	It can be used to determine or estimate uncertainty in data analysis and design.	Fuzzy logic success is dependent on the logical system used.
4.	It is easily explained with the use of fuzzy rules. Etc.	

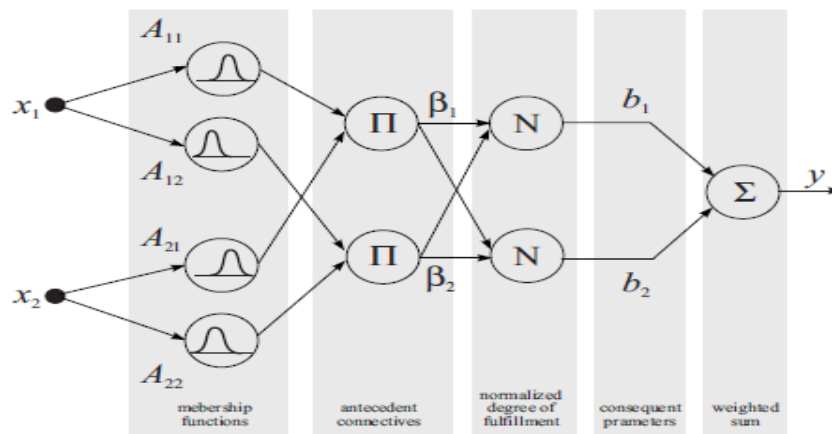

**Fig. 3. Zero-order Takagi-Sugeno fuzzy model [12]**

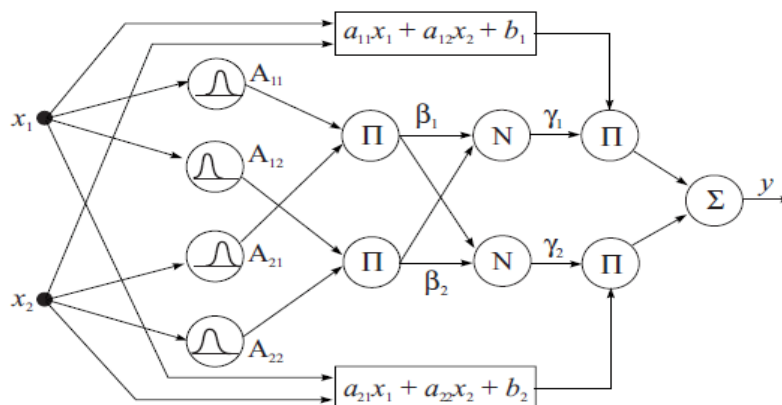

**Fig. 4. Neuro-fuzzy network (ANFIS) [12]**

### 3. MATERIALS AND METHODS

This section is devoted to the materials used in the study, the apparatus deployed and the procedure adopted in the study. It is both an experimental and analytical method. It is a continuous report from the previous works on Valve Actuation using electro-pneumatic actuation technique powered by AI.

#### 3.1 Materials

The study materials for this work includes the actuation chamber, clutch plate, static and dynamic gearing parameters of a Mercedes Benz Actros Truck model MP 2, 2031 from which conventional actuation control parameters were sourced empirically [13]. Artificial Neural Network module was selected in a MATLAB environment.

#### 3.2 Methods

##### 3.2.1 Conventional controller design

Empirical research method was used to obtain the initial data prevalent in the actuator chamber of an Actros Truck model MP 2, 2031. This formed the characterised conventional control data. The details of the characterisation are contained in another work by this Author entitled “Physiological Characterization of Electro-

Pneumatic Clutch Actuation Control System for Heavy-Duty Vehicles”, [14]. Simulink models for conventional controller was designed in a MATLAB 7.5 system. The characterised data for error, speed, torque and power were inserted into the conventional modelled Simulink shown in Fig. 5.

##### 3.2.2 Fuzzy logic control design

Mamdani Technique of Fuzzy inference editor in a MATLAB environment was explored in the development of a rule base for the actuation control of the electro-pneumatic clutch system. Seven input membership functions of fuzzy rules for positional error and change in positional error as inputs were designed. They are negative high (NH), negative medium (NM), negative low (NL), zero (Z), positive low (PL), positive medium (PM), and positive high (PH) respectively. Three output membership functions for sensor monitor as output gain were also designed. They are low (L), medium (M) and high (H) respectively. The rule base for the control mechanism, the actuator control sequence and the rules for the sequence were generated. The rules for the Mamdani Technique of Fuzzy inference editor is shown in Fig. 6 while the fort-nine rules generated is shown in Table 1. The fussy rules are incorporated in a Simulink model as a block unit. Details is contained in [14].

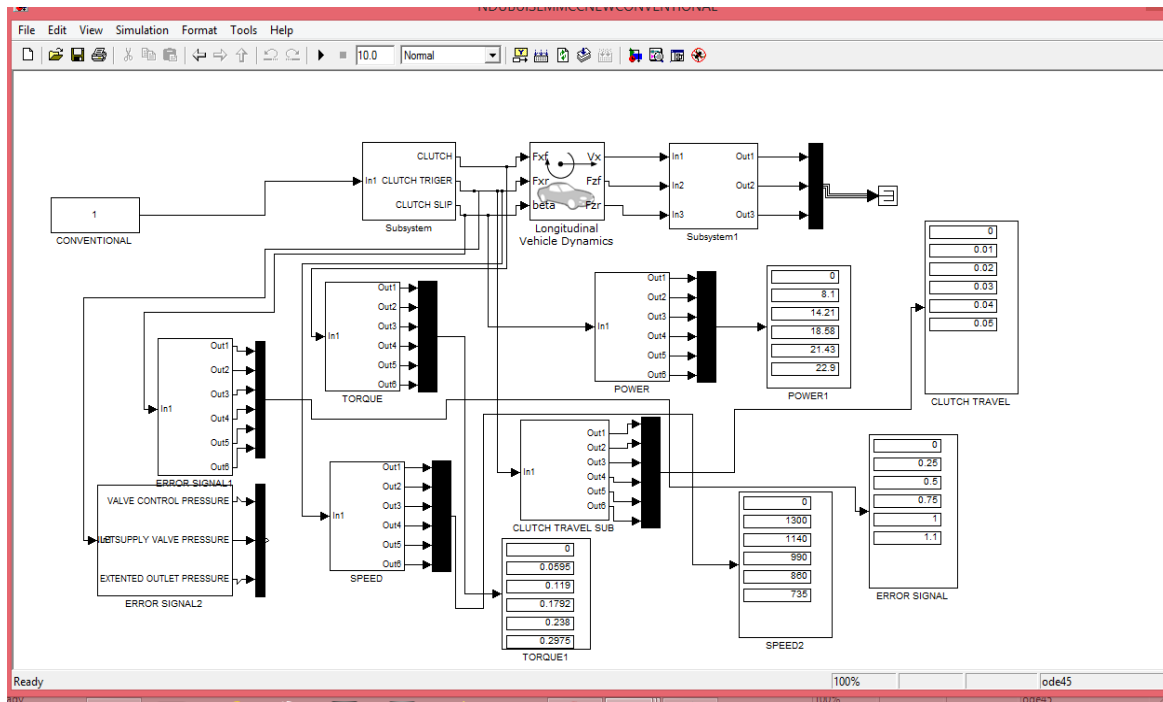

Fig. 5. Model for Conventional Controller

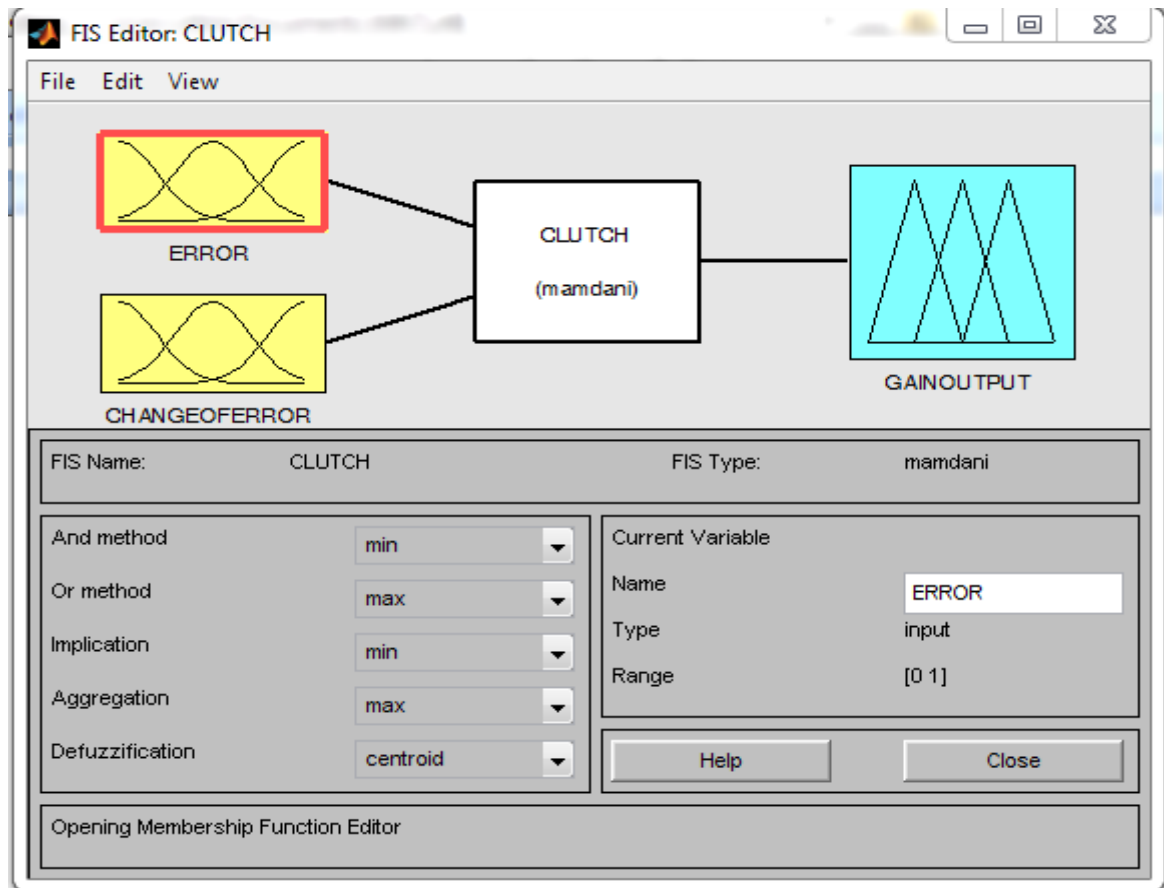

Fig. 6. Fuzzy inference editor for the design of fuzzy rule for an improved control system

Table 1. Summary of the fuzzy rule

S/N	Error	Change In Error	Gain
1	NB	NB	low
2	NB	NM	low
3	NB	NS	low
4	NB	Z	low
5	NB	PS	low
6	NB	PM	low
7	NB	PB	low
8	NM	NB	low
9	NM	NM	average
10	NM	NS	average
11	NM	Z	average
12	NM	PS	average
13	NM	PM	average
14	NM	PB	low
15	NS	NS	high
16	NS	Z	high
17	NS	PS	high
18	NS	PM	high
19	NS	PB	low



S/N	Error	Change In Error	Gain
20	Z	NB	low
21	Z	NM	high
22	Z	NS	high
23	Z	Z	high
24	Z	PB	high
25	PS	NM	average
26	PS	NS	high
27	PS	Z	high
28	PS	PS	high
29	PS	PM	high
30	PS	PB	low
31	PM	NB	low
32	PM	NM	average
33	PM	NS	average
34	PM	Z	average
35	PM	PS	average
36	PM	PM	average
37	PM	PB	average
38	PB	NB	low
39	PB	NM	low
40	PB	NS	low
41	PB	Z	low
42	PB	PS	low
43	PB	PS	low
44	NB	NM	low
45	PB	NS	low
46	PB	Z	low
47	PB	PS	low
48	PB	PM	low
49	PB	PB	low

### 3.2.3 ANN controller design

ANN module was selected in a MATLAB environment. Seven neurons were used as the input neurons into which the two input signals of error and change in error were fed. The back-propagation algorithm technique for weight variations was adopted for its obvious advantage. Similarly, seven neurons formed the output neuron through which the output signal was derived. The hidden neurons were thirty-five. The total number of neurons in the system resulted to forty-nine neurons. This is synonymous to seven neurons trained seven times. The training sessions corresponds with the forty-nine rules of the fuzzy logic system. The Sigmoid activation function ( $\frac{1}{1+e^{-x}}$ ) was adopted. Simulink models for ANN Controller was also designed in a MATLAB 7.5 system and

fed into an ANN block unit. See the details also in [15].

### 3.2.4 Hybrid neuro-fuzzy controller design

Neuro-fuzzy is an amalgamation of both fuzzy logic and ANN blocks through a suitable combiner in a MATLAB 7.5 system. The Neuro-Fuzzy Simulink model controller design was cascaded with the conventional control block in series to the Fuzzy logic block on the upper end and in series also with the ANN block on the lower end. Accordingly, the longitudinal vehicle dynamics building blocks were connected in the design. Subsystem building blocks for error, power, torque, speed and clutch travel parameters were connected. A data input/output subsystem where relevant analytical data for error, speed, torque, power and clutch travel parameters were read, were also connected. The design is shown in Fig. 8.

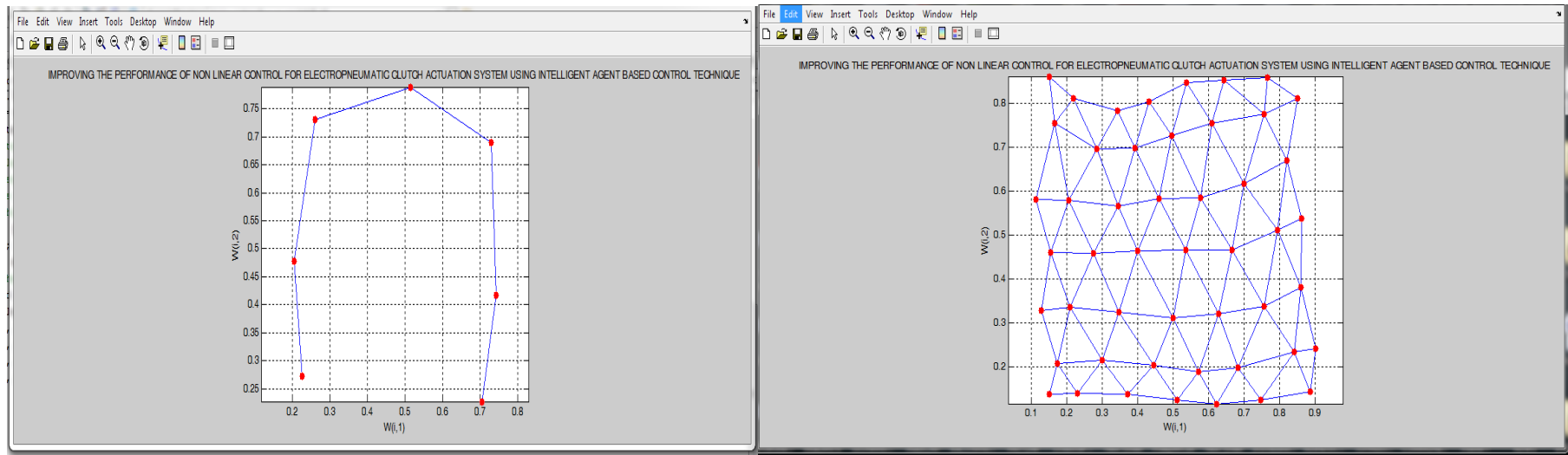

Fig. 7. Neuron arrangement of the first and seventh training in ANN

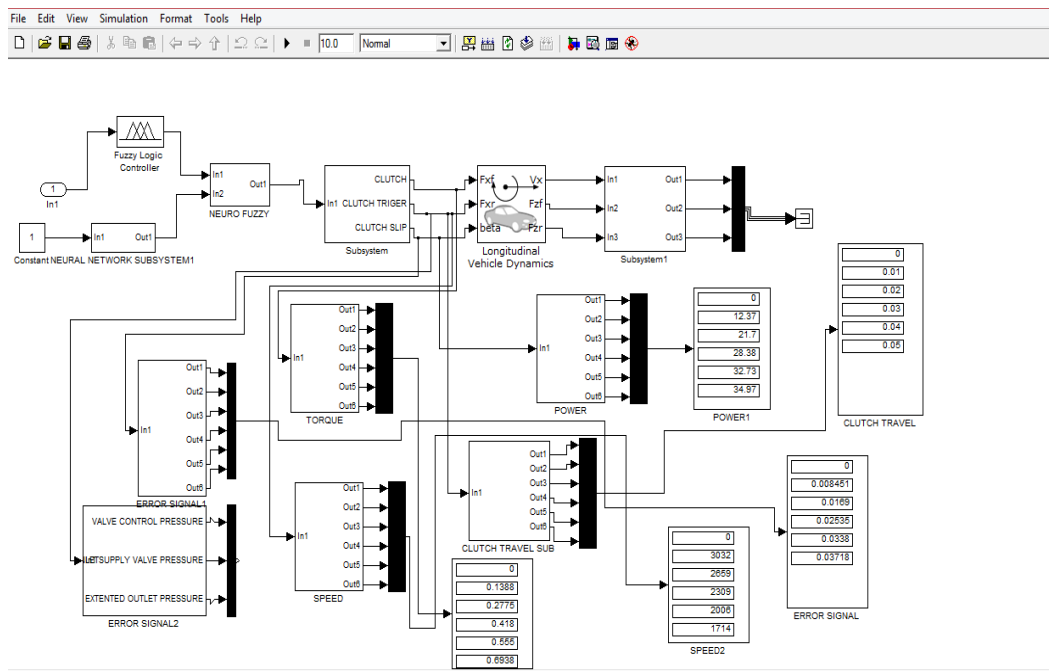

Fig. 8. Designed Neuro-Fuzzy Controller Simulink model for improved clutching

#### 4. RESULTS AND DISCUSSION

The results obtained from designs of the neuro-fuzzy controller is presented and discussed in terms of improved performances of the neuro-fuzzy controller over that of conventional controllers.

##### 4.1 Conventional and Hybrid Neuro-Fuzzy Simulink Data Presentation

Conventional controller and Neuro-Fuzzy controller data for proportional error, engine speed, torque and power obtained from

simulation of designed Simulink are presented in Tables 2 and 3 respectively.

##### 4.2 Conventional and Neuro-Fuzzy Error Signals comparisons

Conventional controller and Neuro-Fuzzy controller data for proportional error is tabulated in Fig 4. furthermore, the graph (a) and bar chart (b) respectively are plotted in Fig 9 for comparison. Conventional data is identified with red plot while green plot represents neuro-fuzzy data.

Table 2. Conventional Controller Simulink model data

Clutch travel (M)	Error signal (mm)	Speed (RPM)	Torque (NM)	Power (kw)
0	0	0	0.0000	0.00
0.01	0.25	1300	0.0595	08.10
0.02	0.50	1140	0.1190	14.21
0.03	0.75	990	0.1792	18.58
0.04	1.00	860	0.2380	21.43
0.05	1.10	735	0.2975	22.90

Table 3. Neuro-Fuzzy Controller Simulink model Data

Clutch travel (M)	Error signal (mm)	Speed (RPM)	Torque (NM)	Power (kw)
0	0	∞	0.0000	0.00
0.01	0.0085	3032	0.1388	12.37
0.02	0.0169	2659	0.2775	21.70
0.03	0.0254	2309	0.4180	28.38
0.04	0.0338	2006	0.5550	32.73
0.05	0.0372	1714	0.6938	34.97

**Table 4. Comparing error signals in electro-pneumatic clutch actuation control system**

Clutch travel (M)/Analysis	Conventional error signal(mm)	Neuro-Fuzzy error signal(mm)
0	0	0
0.01	0.25	0.0085
0.02	0.50	0.0169
0.03	0.75	0.0254
0.04	1.00	0.0338
0.05	1.10	0.0372
Average	0.72	0.0244
Using 100 as datum	100	100
% Difference	-28.0	-97.56

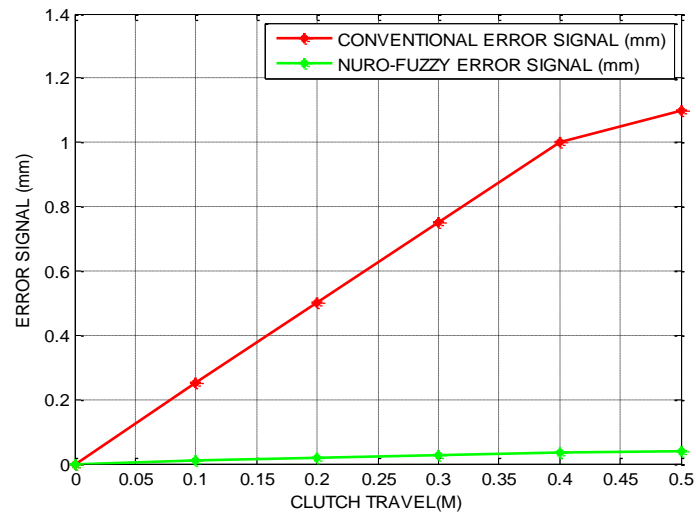

(a) Graph

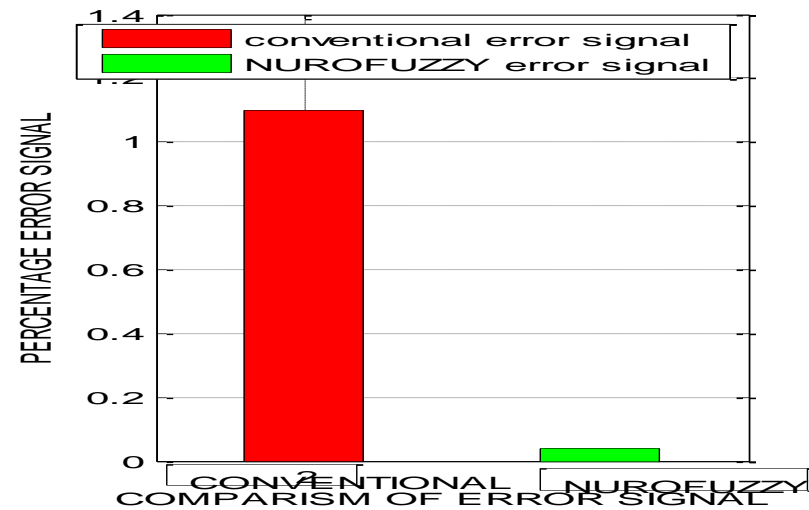

(b) Bar Chart

**Fig. 9. Conventional and Artificial Neural Network controller compared for error signal**

**Table 5. Comparing engine angular speed in electro-pneumatic clutch actuation control**

Clutch travel (M)/Analysis	Conventional Speed (RPM)	Neuro-Fuzzy speed (RPM)
0.00	$\infty$	$\infty$
0.01	1300	3032
0.02	1140	2659
0.03	990	2309
0.04	860	2006
0.05	735	1714
Average	1005	2344
% Difference	0	133.23
Using 100 as datum	100	233.23

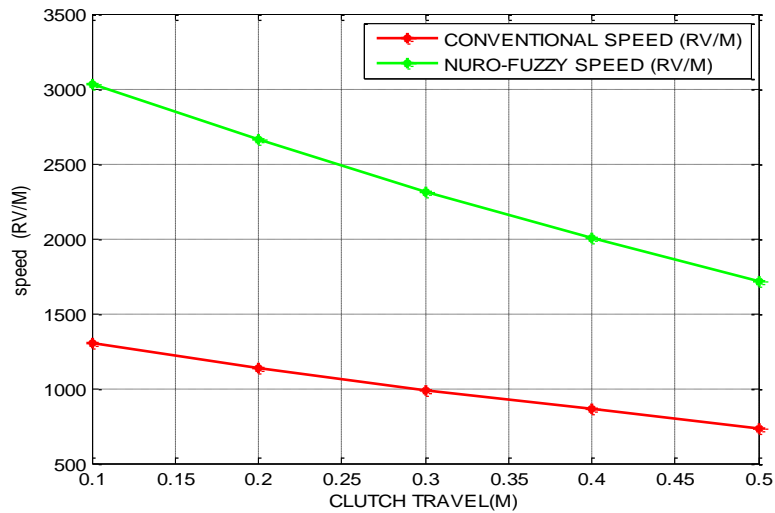

**(a) Graph**

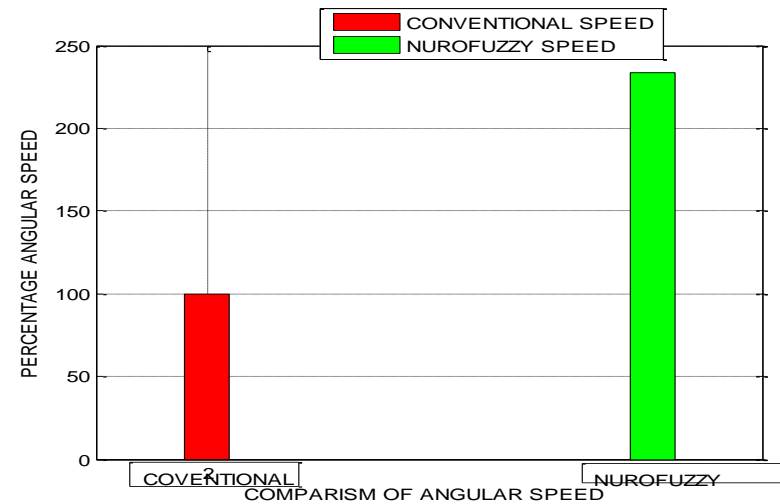

**(b) Bar Chart**

**Fig. 10. Conventional and Neuro-Fuzzy Compared for Angular Speed**

**Table 6. Comparing engine torque in electro-pneumatic clutch actuation control**

Clutch travel (M)/Analysis	Conventional torque (NM)	Neuro-Fuzzy torque (NM)
0.00	0.0000	0.0000
0.01	0.0595	0.1388
0.02	0.1190	0.2775
0.03	0.1792	0.4180
0.04	0.2380	0.5550
0.05	0.2975	0.6938
Average	0.1786	0.4166
% Difference	0	133.26
Using 100 as datum.	100	233.26

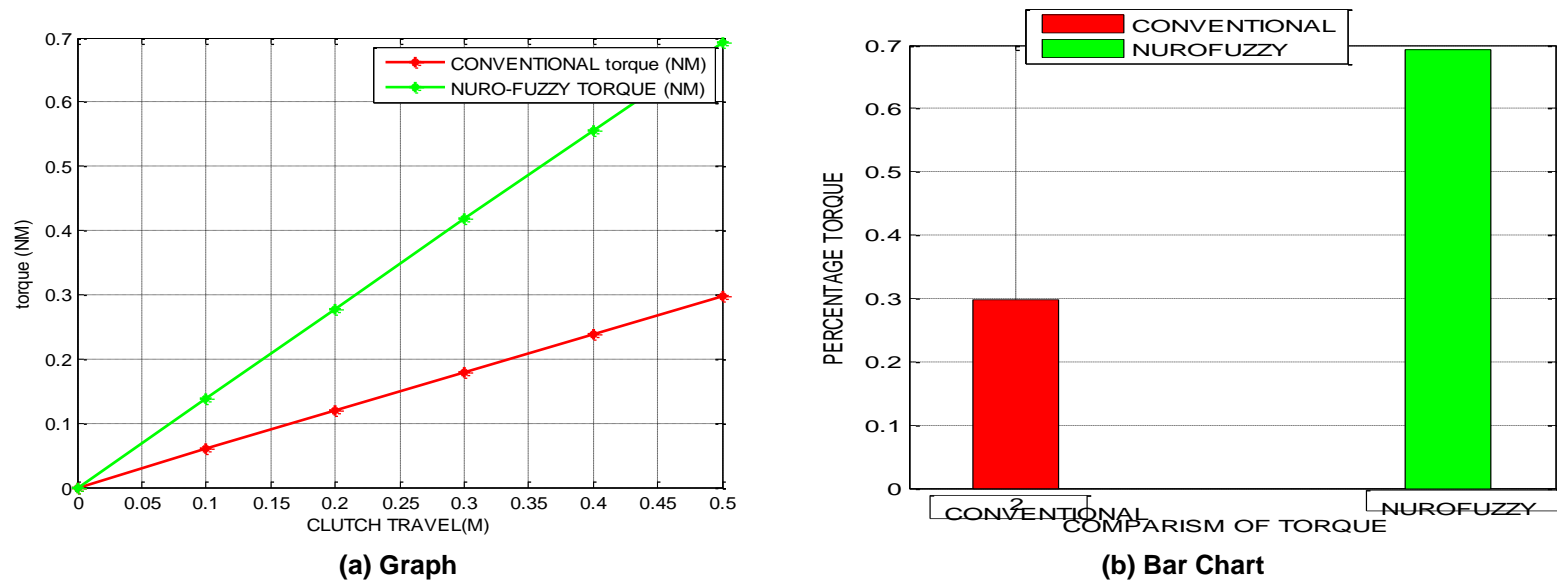

**Fig. 11. Conventional and Neuro-Fuzzy Controller compared for Engine Torque**

**Table 7. Comparing engine power in electro-pneumatic clutch actuation control**

Clutch travel (M)/Analysis	Conventional power (kw)	Neuro-Fuzzy power(kw)
0.00	0.00	0.00
0.01	08.10	12.37
0.02	14.21	21.70
0.03	18.58	28.38
0.04	21.43	32.73
0.05	22.09	34.97
Average	16.88	26.03
% Difference	0	54.21
Using 100 as datum.	100	154.21

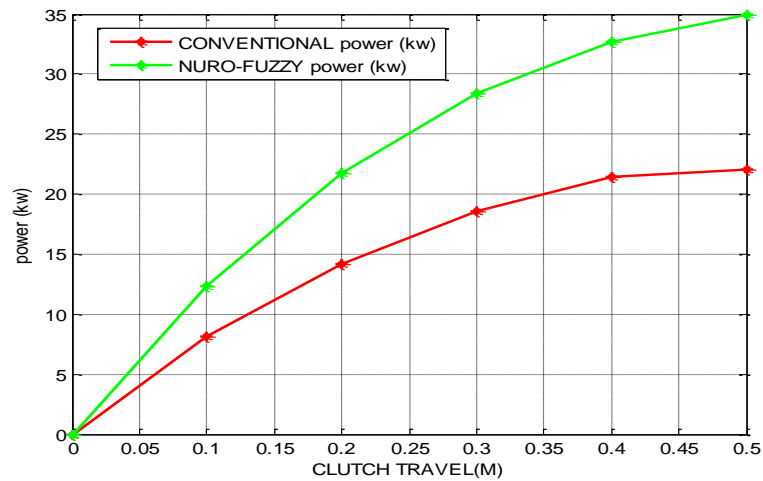

**(a) Graph**

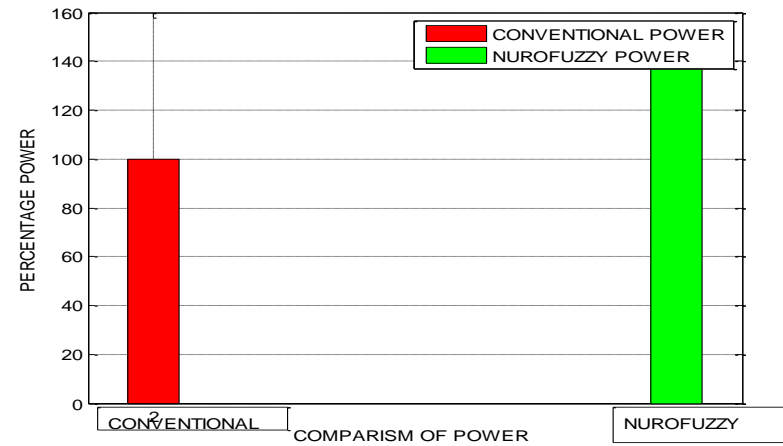

**(b) Bar Chart**

**Fig. 12. Conventional and Neuro-Fuzzy Controller compared for Engine Power**

### 4.3 Conventional and Neuro-Fuzzy Angular Speed Comparisons

Table 5 presents the data for angular speed in a conventional controller in comparison with that obtained from a neuro-fuzzy controller. The graph and bar chart of Figs. 10 (a) and (b) respectively are used to illustrate the trend. Conventional data is identified with red plot while green plot represents neuro-fuzzy data.

### 4.4 Conventional and Neuro-Fuzzy Engine Torque Comparisons

The data for engine torque in a conventional controller in comparison with that obtained from a neuro-fuzzy controller is presented in Table 6. The graph and bar chart of Figs. 11 (a) and (b) respectively are used to illustrate the trend. Conventional data is identified with red plot while green plot represents neuro-fuzzy data.

### 4.5 Conventional and Neuro-Fuzzy Engine Power Comparisons

The data for engine power in a conventional controller is compared with that obtained from a neuro-fuzzy controller in the presentation of Table 6. The graph and bar chart of Figs. 12 (a) and (b) respectively are used to illustrate the trend. Conventional data is identified with red plot while green plot represents neuro-fuzzy data as is usual throughout this presentation [16-19].

## 5. CONCLUSION

The different improvement recorded in the various parameters of error, angular speed, engine torque and power respectively with the Hybrid Neuro-Fuzzy controllers show clear improvements over the conventional controller. The mean improvement on conventional controllers were remarkable. The Hybrid Neuro-Fuzzy improved controllers stood at an error reduction in clutch travel from 0.720mm to 0.0244mm given a decrease of 96.6% or error reduction to a level of only 3.39 %. The angular speed increased from 1005 RPM to 2344 RPM or an increase of 133.23%. The torque was increased from 0.1786 NM to 0.4166 NM or 133.26%. Similarly, power increased from 16.88 kilowatts to 26.03 kw or 54.21% increase. These results depicts conclusively that Hybrid Neuro-Fuzzy controller application in intelligent clutch actuation control of an electro-pneumatic clutch

system for heavy-duty vehicle will have over the use of a single mode of either fuzzy logic or Artificial Neural Network.

## DISCLAIMER (ARTIFICIAL INTELLIGENCE)

Author(s) hereby declare that NO generative AI technologies such as Large Language Models (ChatGPT, COPILOT, etc) and text-to-image generators have been used during writing or editing of this manuscript.

## ACKNOWLEDGEMENT

The Management and Staff of Tetralog Nigeria Limited Enugu that permitting us to use their factory including access to the test truck, Mercedes Benz Actros Truck model MP 2,2031 for the field research is highly appreciated. Our special thanks go to the Managing Director, Engr. Onuora Nnabugo and His team of Staff including the Service Manager- Engr. E. Obielika, the Assistance Service Manager Engr. D. Gitau and the Training Manager – Mr. C. Nwinyi. My gratitude goes to the field staff; made up of Mr. J. Nwachukwu, Mr. M. Ogbonna and several others for their humility and untiring commitment to this project. I wish to also appreciate the contributions of Engr. G. U. Ezeatu of ANAMMCO Enugu and Engr. Amasha Olakunle of Innoson Industries Limited, Enugu.

## COMPETING INTERESTS

Authors have declared that no competing interests exist.

## REFERENCES

1. Li-kun Y, He-yan L, Mehdi A and Biao M. Analysis of the influence of engine torque excitation on clutch judder, Journal of Vibration and Control. 2015;1–11, sagepub.co.uk/journals DOI:10.1177/1077546315582291,jvc.sagepub.com Available:https://www.researchgate.net/publication/281316562
2. Mishra P. Types of clutches. Mechanical Booster; 2014-July. Available:https://www.mechanicalbooster.com/2014/07/types-of-clutches.htm
3. Barma S, Huba N, Kalman K. Observer based feedforward/feedback control of electro-pneumatic clutch systems. Ph.D.



- Dissertation, Department of Automobiles and Vehicle Manufacturing, Budapest, Hungary; 2015.  
Available:<https://repozitorium.omikk.bme.hu/bitstream/handle/10890/1437/ertekezes.pdf?sequence=2&isAllowed=y> 18 Apr 2015.
4. Carlos G. What is the difference between pneumatic, hydraulic and electrical actuators, machine Design. com. Powered by Penton; 2016.  
Available:<https://www.htlgroup.com/general/the-difference-between-pneumatic-hydraulic-and-electrical>
  5. Federal Road Safety Corps Annual Report. Articulated Lorries Management in Nigeria: Road Safety Perspective. 3<sup>rd</sup> Annual Lecture Series. 2011;54-55.
  6. Nice K, Bryant CW. How clutches work. Howstuffworks Auto; 2019.  
Available:<https://www.howstuffwork.com/clutch-2.htm>
  7. Samson AG. Control valve accessories, electro-pneumatic positioner. Samson Controls, Samson Product Group, Texas, USA; 2019.  
Available:<https://www.samsongroup.com/document/k00200en.pdf>
  8. Calibrating the Clutch Actuator: Sachs Workshop Tip: Calibrating ConAct, the Pneumatic Clutch Actuation System, ZF Vision Magazine; 2019.  
Available:<https://aftermarket.zf.com/go/en/sachs/technology-in-practice/workshop-tips/clutch-s>
  9. Clutch Problems, Trouble Shooting and Service: The Good heart-Willcox co.Inc; 2019.  
Available:<https://docplayer.net/2728280-Clutch-problems-troubleshooting-and-service.html>
  10. Overview of all Workshop Tips on Clutches and Repairs Tips for clutch Systems: Workshop Tips on Clutch from ZF Aftermarket, Sachs Technology; 2019.  
Available:<https://aftermarket.zf.com/go/en/sachs/technology-in-practice/workshop-tips/clutch-system>
  11. Fuller R. Neuro-fuzzy methods. Vacation School Lecture on Neuro-Fuzzy Methods for Modelling & Fault Diagnosis. Lisbon, August 31 and September 1, Eötvös Loránd University, Budapest; 2001.  
Available:<http://uni-obuda.hu/users/fuller.robert/dam.pdf>
  12. Babuska R. Neuro-fuzzy methods for modelling and identification, control systems engineering group, P.O. Box 5031, 2600 GA Delft, Faculty of Information Technology and Systems, Delft University of Technology, The Netherlands, e-mail: R.Babuska@dcsc.tudelft.nl; 2002.  
Available:<http://hilbert.mat.uc.pt/~softcomplex/Docs/RobertBabuska03.pdf>.
  13. Ndubuisi PDI, Mbabuike I, Isaac RO, Agwo JN, Arua JE: Physiological characterisation of electropneumatic clutch actuation system for heavy duty vehicles, World Journal of Engineering Research and Technology. 2023;9(5):09-21.  
April, ISSN 2454-695X, SJIF Impact Factor: 5.924,  
Available:[Www.Wjert.Org](http://www.wjert.org)
  14. Ndubuisi PDI, Nwoke ON, Arua JE. Fuzzy logic improved control design for electro-pneumatic clutch actuation system in heavy duty vehicles, International Journal of Innovations in Engineering and Science, Innovative Research for Development website:[www.ijiesonline.org](http://www.ijiesonline.org) e-issn: 2616-1052. 2023;2(1):79-90, October.
  15. Ndubuisi PDI, Nwoke ON, Arua JE, Elujoba OI. Improving the electro-pneumatic clutch actuation control system of a heavy-duty vehicles using artificial neural network, GSC Advanced Research and Reviews, 2024. 2024;19(03):018-030.  
Available:<https://doi.org/10.30574/gscarr.2024.19.3.0175>, June
  16. Ndubuisi, Paul-Darlington Ibemezie, et al. Improving the electro-pneumatic clutch actuation control system of a heavy-duty vehicles using artificial neural network. GSC Advanced Research and Reviews. 2024;19(3):018-030.
  17. Biswas, Atriya, Aashit Rathore, and Ali Emadi. Coordinated clutch actuation for drivability improvement and energy management of a novel multi-mode hybrid electric vehicle and HIL validation. Energy Conversion and Management. 2023;287: 117060.
  18. Wang Yue, et al. Adaptive pressure control of the clutch hydraulic actuator in wet dual clutch transmission based on TS Fuzzy Model and Extended State Observer. IEEE Access; 2023.

19. Formento, Cecilia, Antonio Tota, Mauro Velardocchia. Analysis of engine braking system for heavy vehicle performance improvement. The International Conference of IFToMM ITALY. Cham: Springer Nature Switzerland; 2024.

**Disclaimer/Publisher's Note:** The statements, opinions and data contained in all publications are solely those of the individual author(s) and contributor(s) and not of the publisher and/or the editor(s). This publisher and/or the editor(s) disclaim responsibility for any injury to people or property resulting from any ideas, methods, instructions or products referred to in the content.

---

© Copyright (2024): Author(s). The licensee is the journal publisher. This is an Open Access article distributed under the terms of the Creative Commons Attribution License (<http://creativecommons.org/licenses/by/4.0>), which permits unrestricted use, distribution, and reproduction in any medium, provided the original work is properly cited.

*Peer-review history:*  
*The peer review history for this paper can be accessed here:*  
<https://www.sdiarticle5.com/review-history/124244>